

REVISIONS			
REV	DESCRIPTION	DATE	APPROVED
1	ADDED AMP_ON LINE	6-25-96	DLISOLT

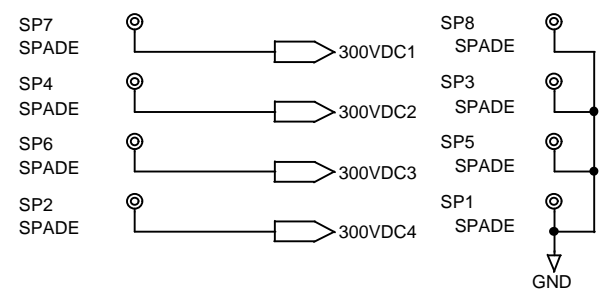

TO POWER SUPPLY

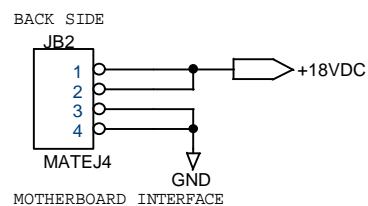
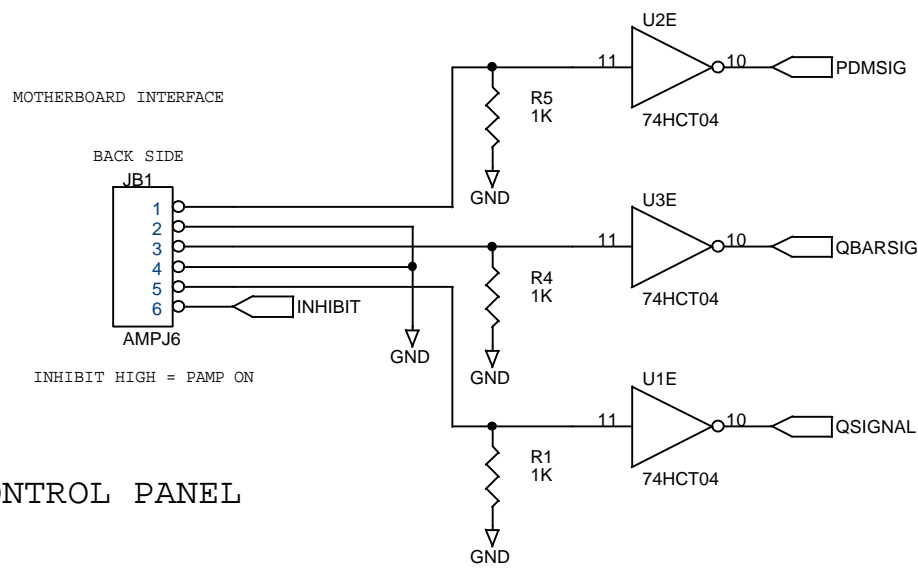

TO CONTROL PANEL

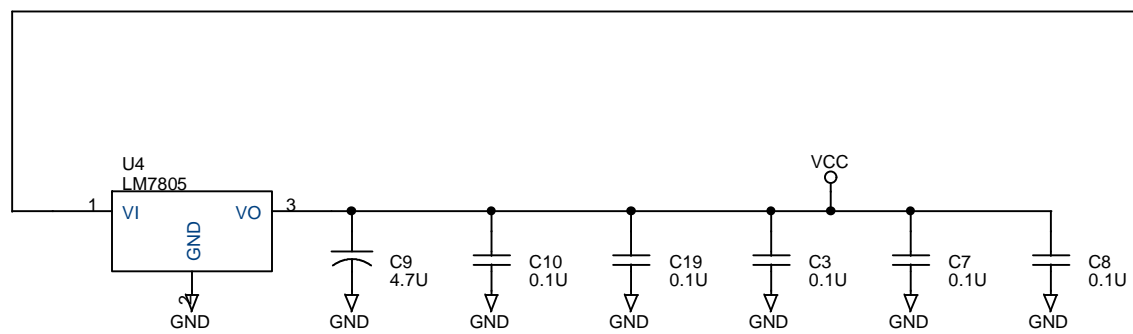
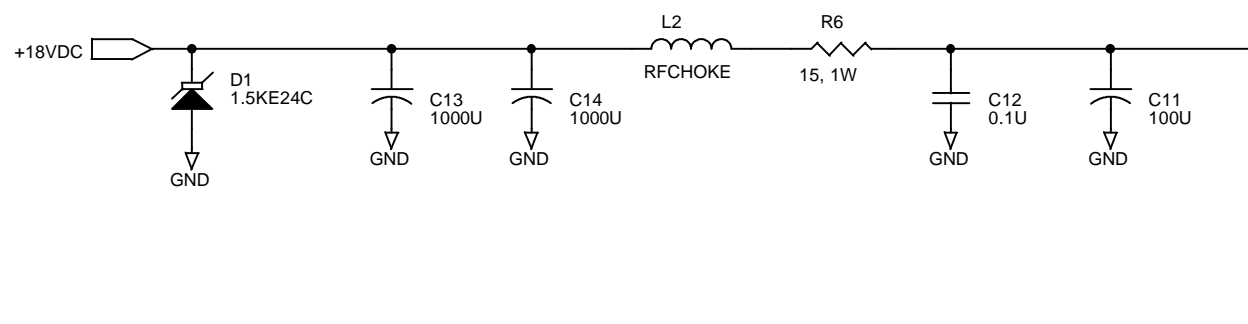
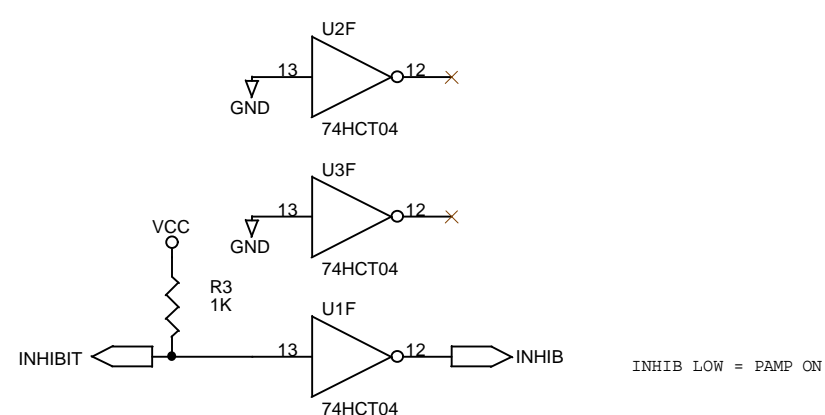

NOTE: RESISTANCE IN OHMS, CAPACITANCE IN FARADS, INDUCTANCE IN HENRIES UNLESS OTHERWISE NOTED.

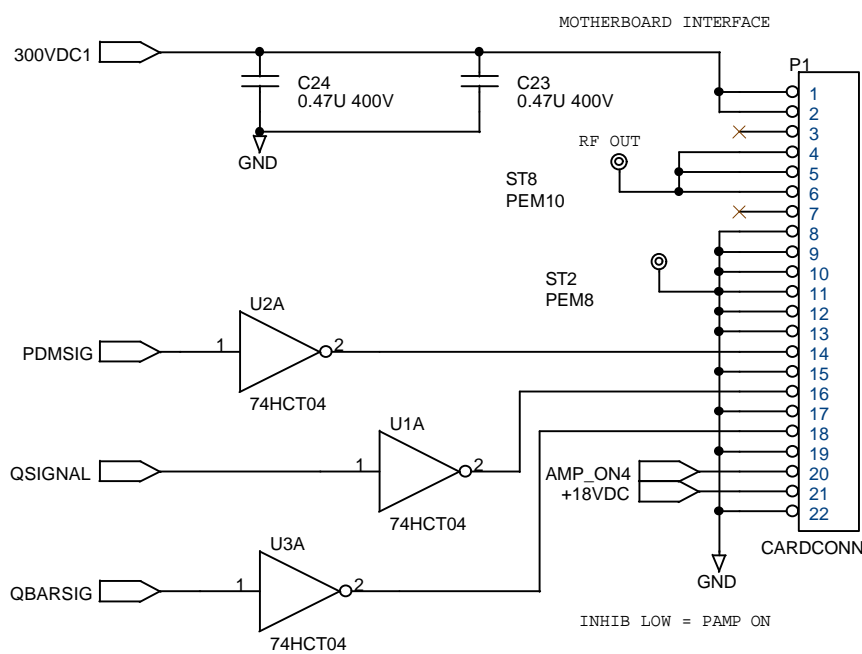

TO POWER AMP 1

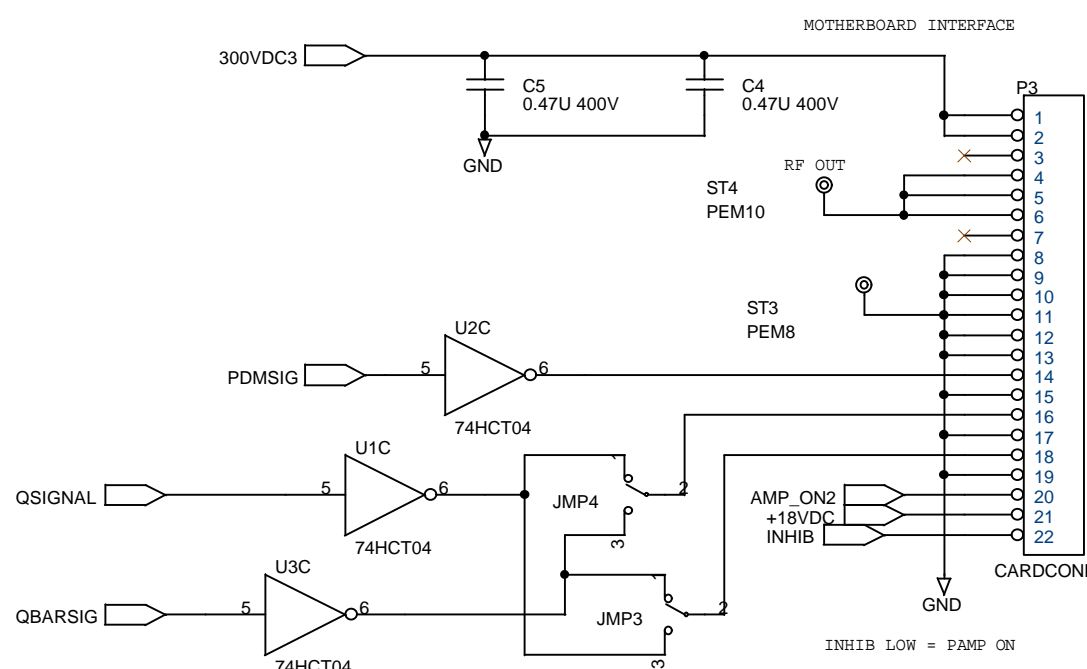

TO POWER AMP 3

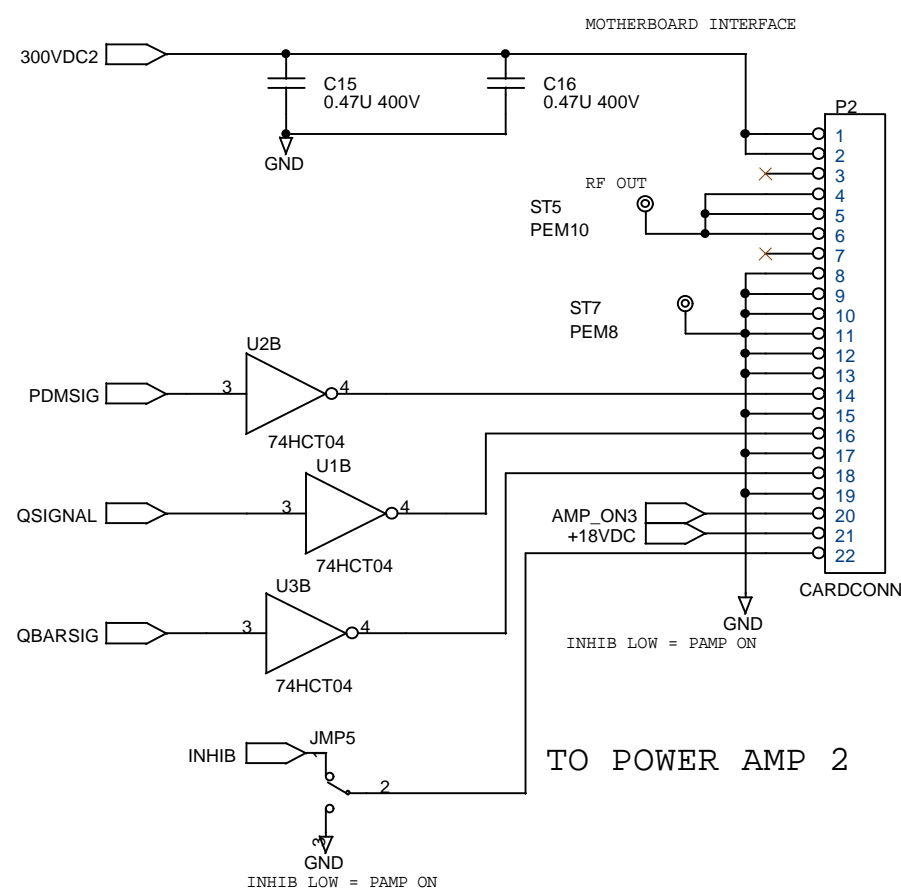

TO POWER AMP 2

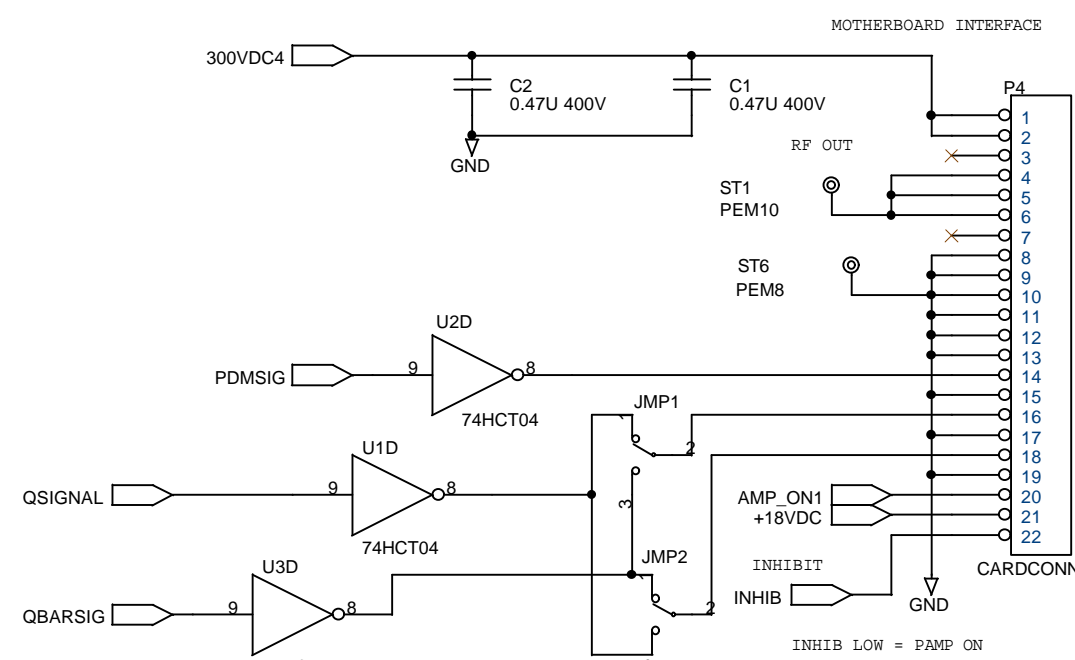

TO POWER AMP 4

JMP'S IN UPPER POSITION FOR IN-PHASE WILKINSON COMBINER
JMP'S IN LOWER POSITION FOR OUT-OF-PHASE BROADBAND COMBINER

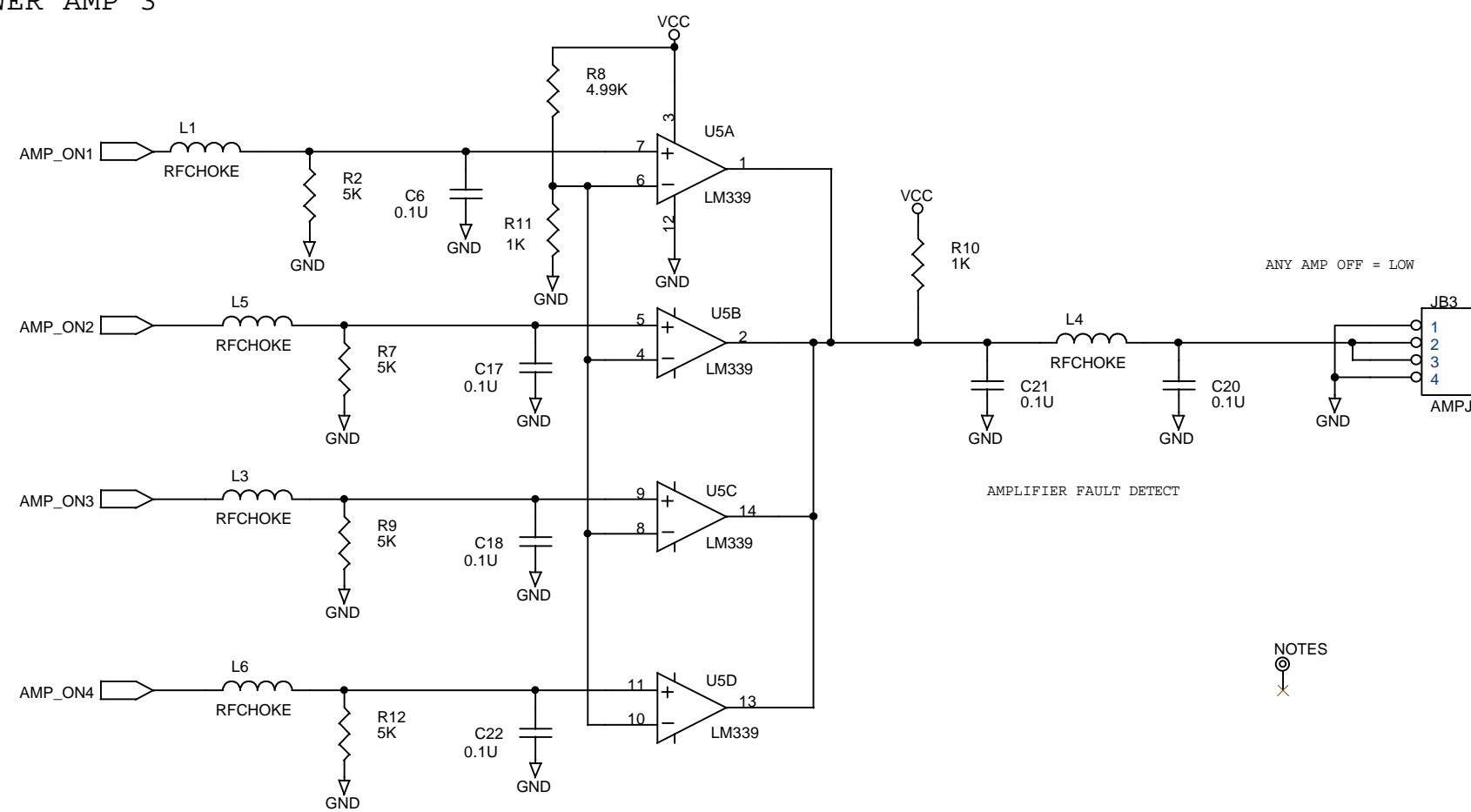

NOTES

LPB Communications Inc 960 Brook Road Unit #5 Conshohocken PA 19428		
Title 3KW Power Amp Panel Motherboard		
Size	Document Number	Rev
Custom	S-213-300	1
Date: Monday, February 25, 2002	Sheet	1 of 1