

REVISIONS

REV	DESCRIPTION	DATE	APPROVED
1	REVISED NEW TECH WIRING CHANGES	8-15-96	JJSOLT
2	WIRING CHANGE FOR AMPFAULT	10-8-96	JJSOLT
3	CHANGED TO HYBRID COMB SCHEMATIC REDRAWN	10-19-98 3-9-00	DLSOLT WBORTH

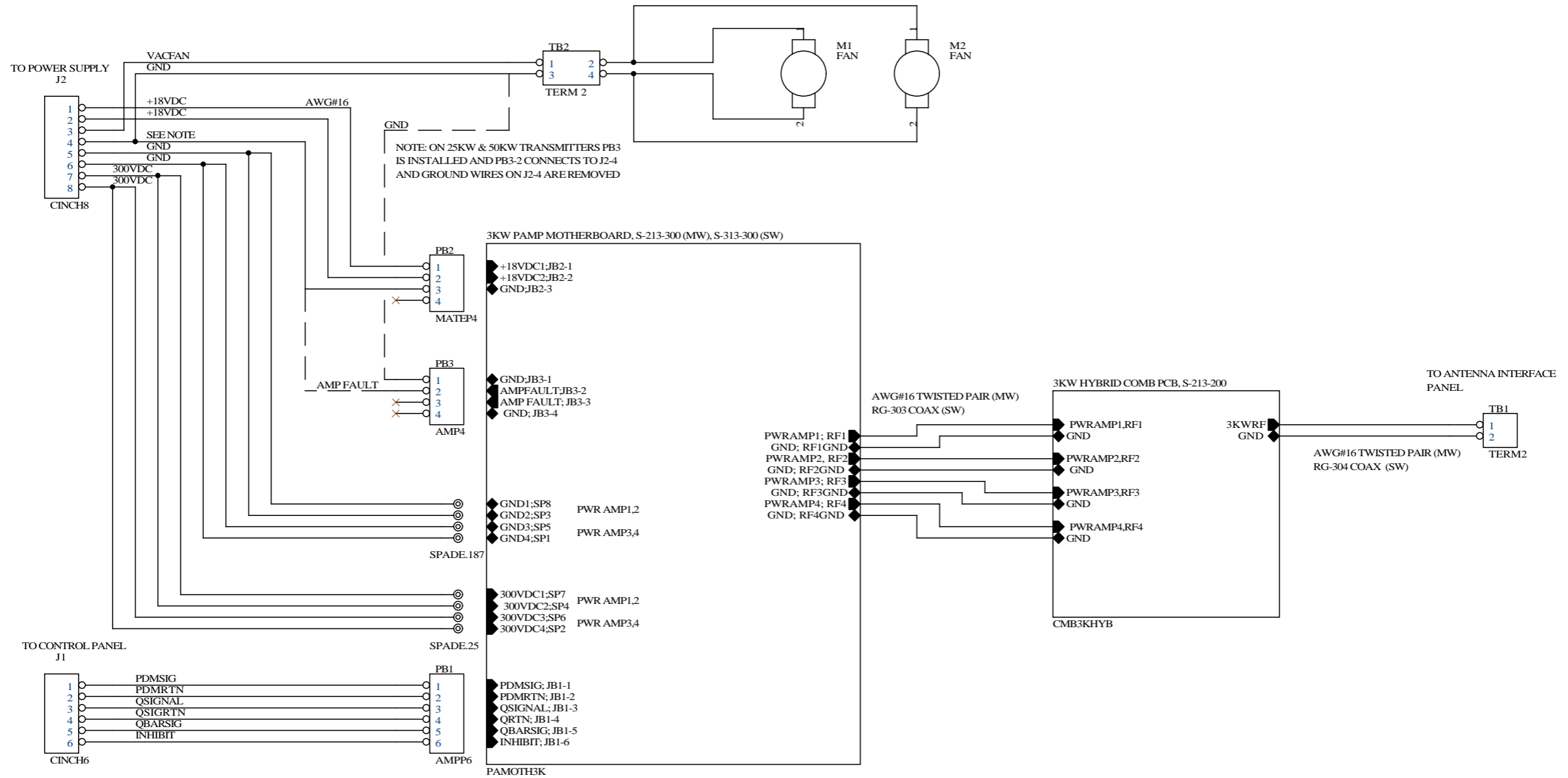

NOTE: RESISTANCE IN OHMS, CAPACITANCE IN FARADS, INDUCTANCE IN HENRIES UNLESS OTHERWISE NOTED.

OMNITRONIX, INC.

113 Dickerson Road, North Wales, Pennsylvania, 19454 (c) Copyright 1999

Title
3KW BROADBAND PWR AMP COMBINER PANEL

Size Document Number
Custom **S-213-000** Rev 3

Date: Friday, October 27, 2000 Sheet 1 of 1