

## REVISIONS

REV	DESCRIPTION	DATE	APPROVED
1	SEE CHANGE ORDER 1126-01	02-08-91	DLSOLT
2	CHANGE REF & DOC NUMBERS	11-15-91	DLSOLT
3	ADD STATUS LEDS	12-2-93	DLSOLT

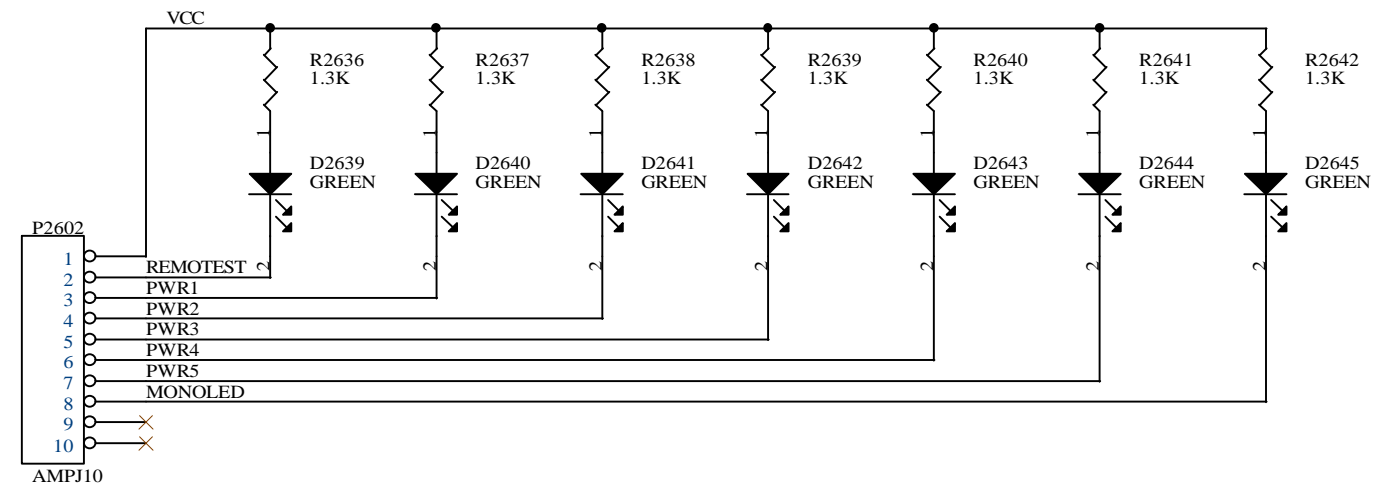
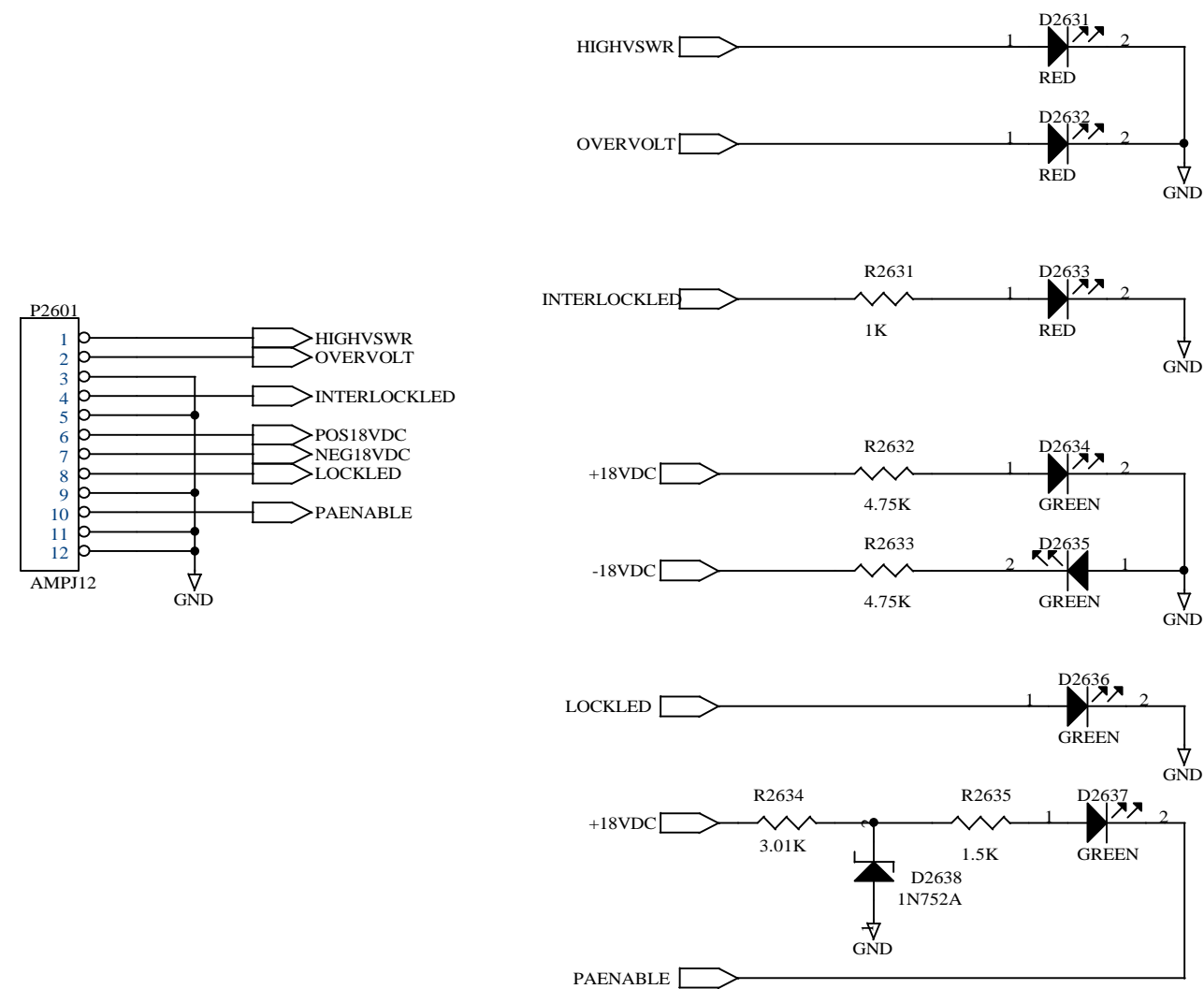

NOTE: UNLESS OTHERWISE SPECIFIED  
 CAPACITANCE IN FARADS  
 INDUCTANCE IN HENRIES  
 RESISTANCE IN OHMS

**LPB Communications, Inc.**  
 960 Brook Road Unit #5 Conshohocken PA 19428

Title <b>CONTROL FRONT PANEL LED PCB</b>		
Size B	Document Number <b>S-112-610</b>	Rev 3
Date: Thursday, October 26, 2000      Sheet 1 of 1		