

| REVISIONS | | | |
|-----------|---|----------|----------|
| REV | DESCRIPTION | DATE | APPROVED |
| 1 | SEE CHANGE ORDER 1123-01 | 02-08-91 | DLSOLT |
| 2 | ADDED ONE SHOT TO TXINHIBIT | 10-22-91 | DLSOLT |
| 3 | CHANGED U2301 TO 74LS04 ADD HIGH VOLT INHIBIT AND DELAY CHANGE R49 FROM 1K TO 10K | 11-12-95 | DLSOLT |

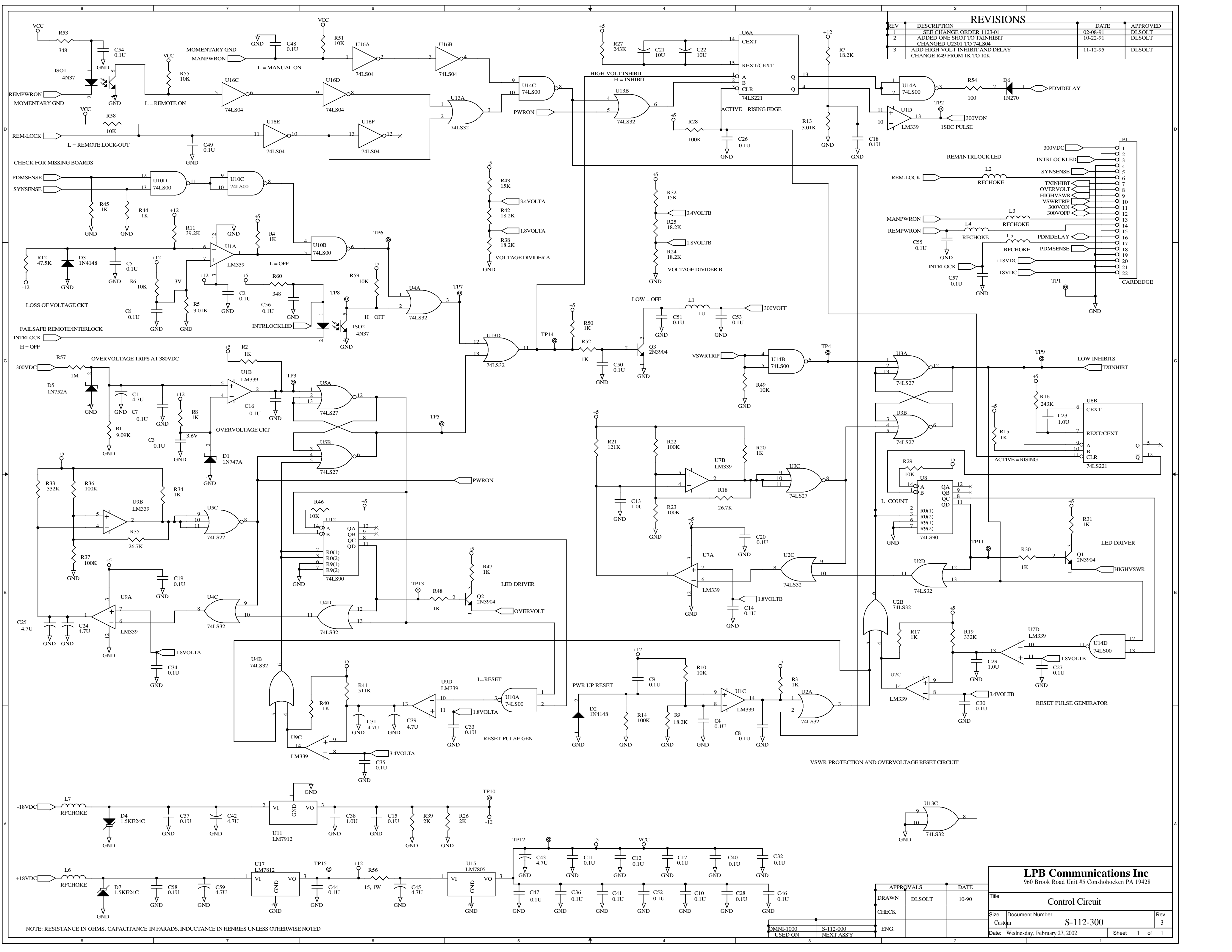

NOTE: RESISTANCE IN OHMS, CAPACTANCE IN FARADS, INDUCTANCE IN HENRIES UNLESS OTHERWISE NOTED

| | | | |
|----------------------|------------------------|------|--|
| OMNI-1000 USED ON | S-112-000 NEXT ASSY | ENG. | |
|----------------------|------------------------|------|--|

| APPROVALS | DATE |
|---------------|-------|
| DRAWN: DLSOLT | 10-90 |
| CHECK: | |

| | |
|---|----------------------------|
| LPB Communications Inc 960 Brook Road Unit #5 Conshohocken PA 19428 | |
| Title: Control Circuit | |
| Size: Custom | Document Number: S-112-300 |
| Date: Wednesday, February 27, 2002 | Rev: 3 |
| Sheet: 1 of 1 | |