

REV	DESCRIPTION	DATE	APPROVED
1	SEE CHANGE ORDER 1110-01	02-08-91	DLSOLT
2	MOVED VAC2 THRU K2 CB1009 TO 5A	3-25-92	JJSOLT
3	CORRECTED VAC2, CLARIFIED DWG	2-11-93	JJSOLT
4	EXT REVISED ADDED DUAL XFMRs	6-30-95	JJSOLT
5	ADDED C8 - CHANGED VALUE RV1, CB12; CHANGED REF #S, REMOVED CB1005, RV1002	3-27-00	RWBORTH

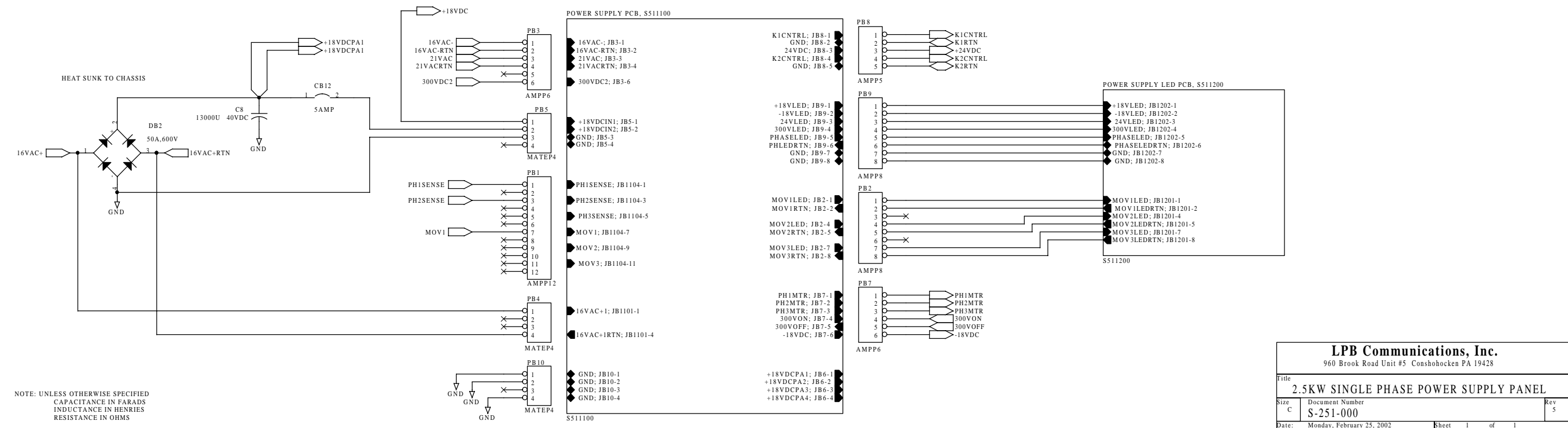
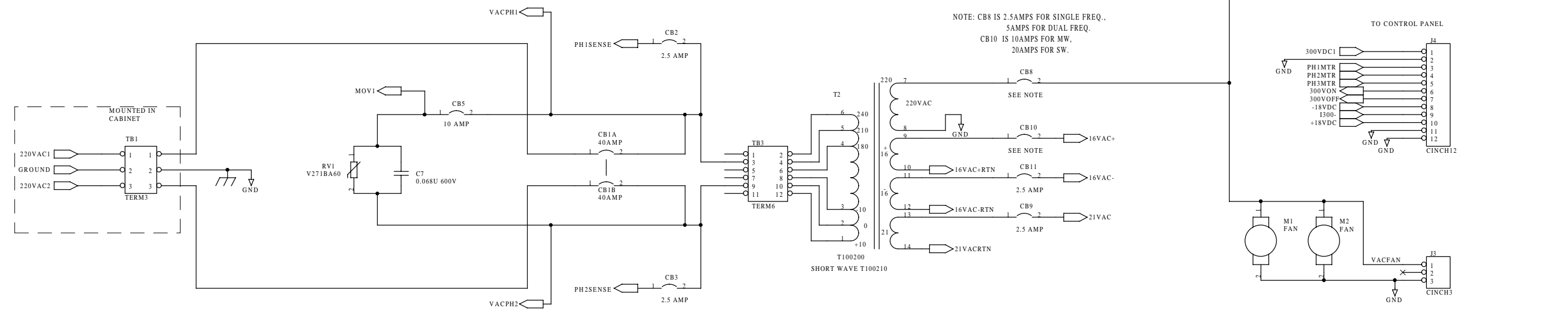
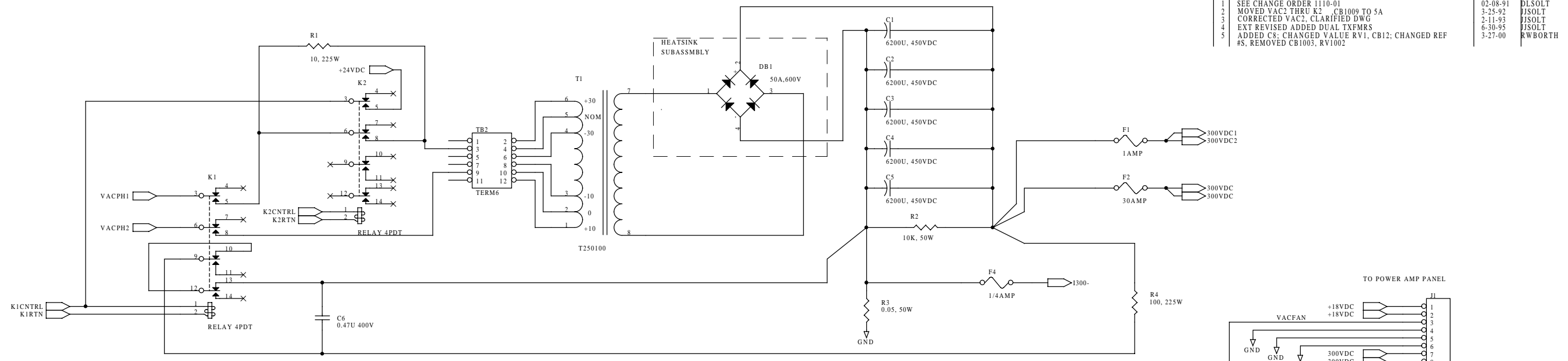

NOTE: UNLESS OTHERWISE SPECIFIED
CAPACITANCE IN FARADS
INDUCTANCE IN HENRIES
RESISTANCE IN OHMS

LPB Communications, Inc.
960 Brook Road Unit #5 Conshohocken PA 19428

2.5KW SINGLE PHASE POWER SUPPLY PANEL

Size C Document Number S-251-000 Rev 5

Date: Monday, February 25, 2002 Sheet 1 of 1