

REV	DESCRIPTION	DATE	APPROVED
1	Added circuits for digital meters	08.02.02	JB

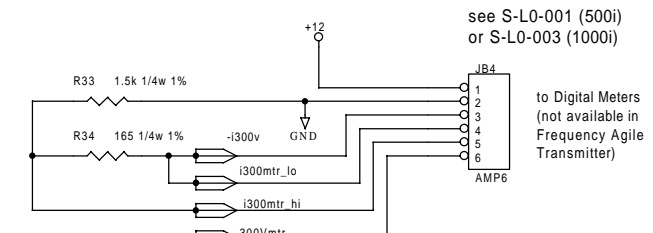
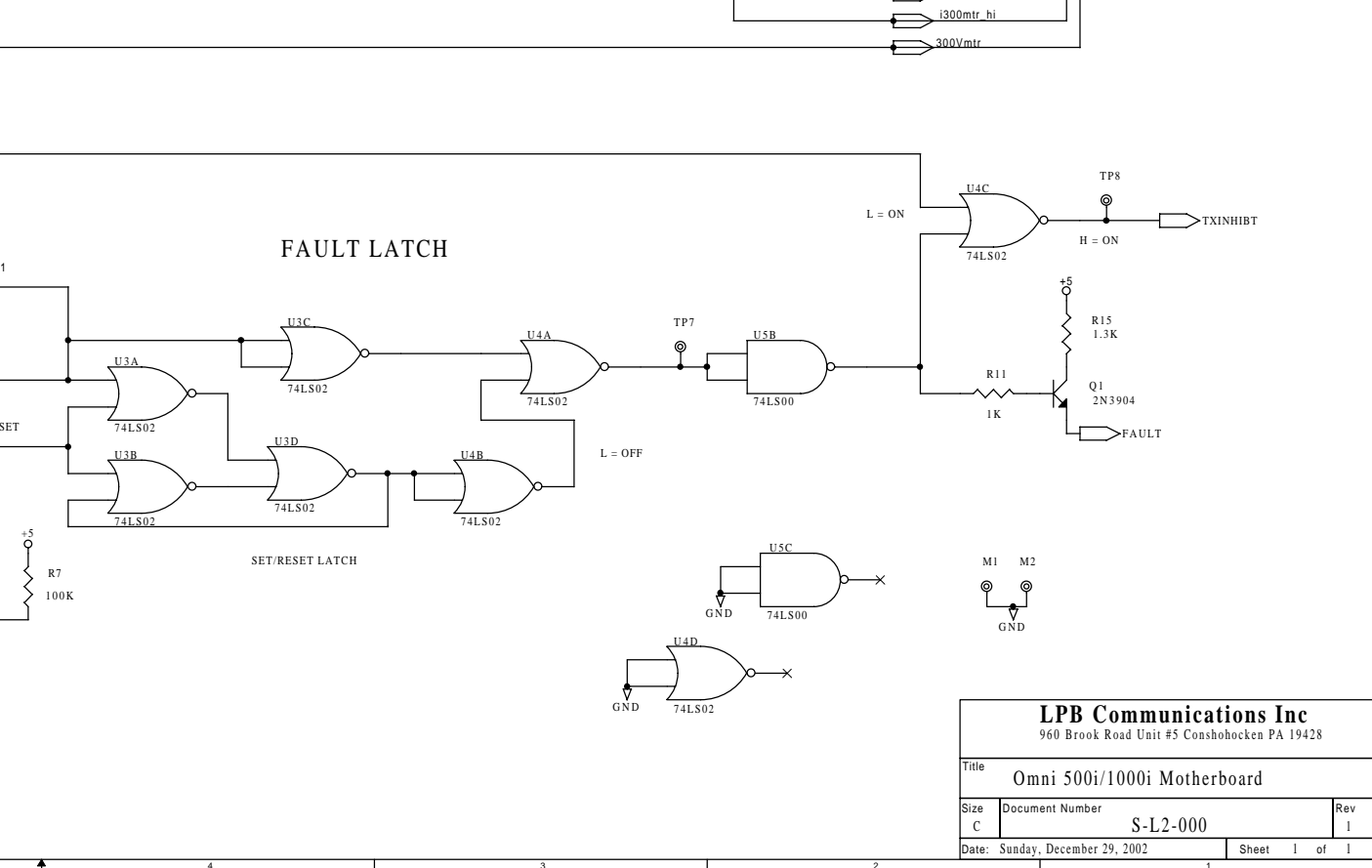
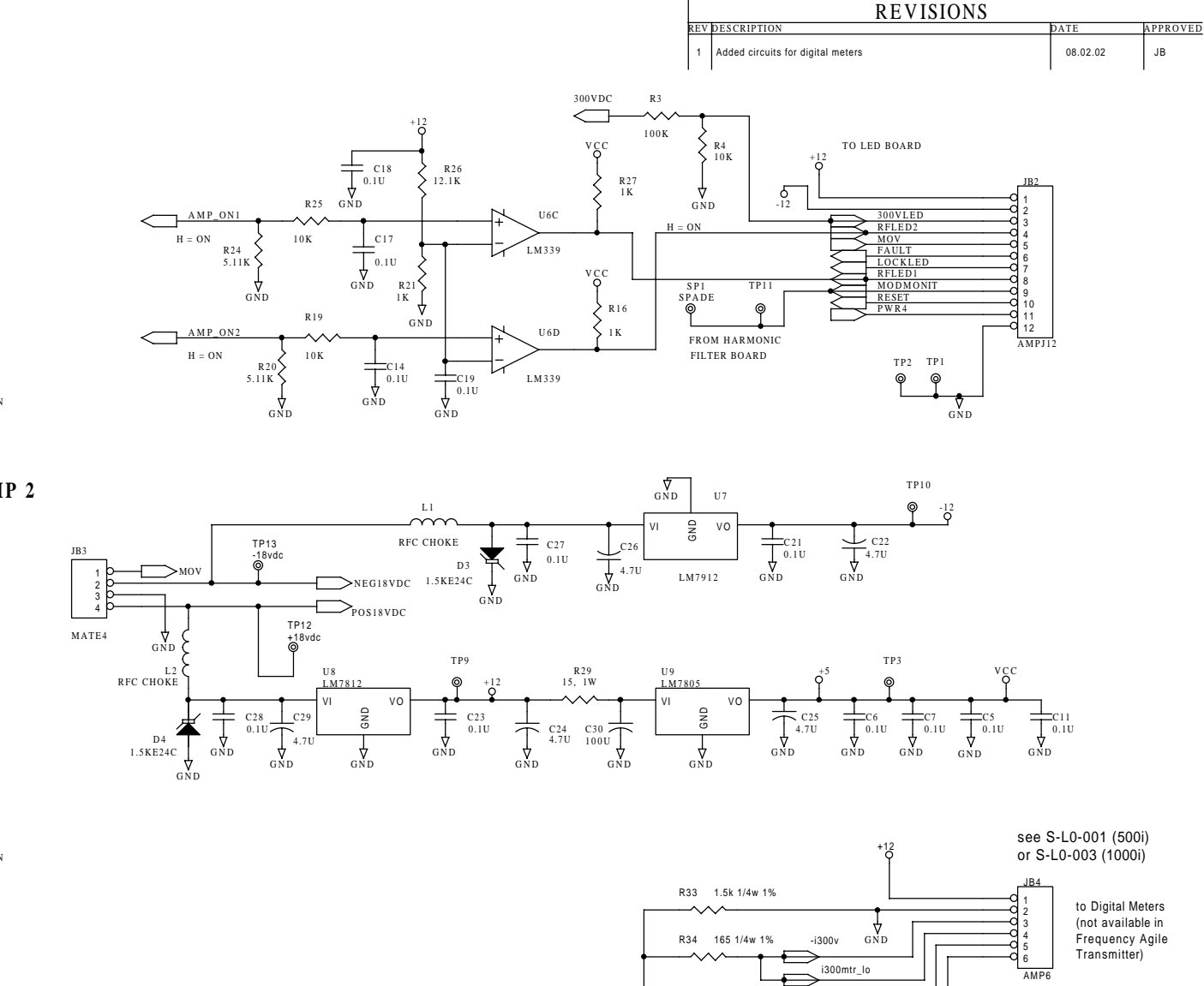
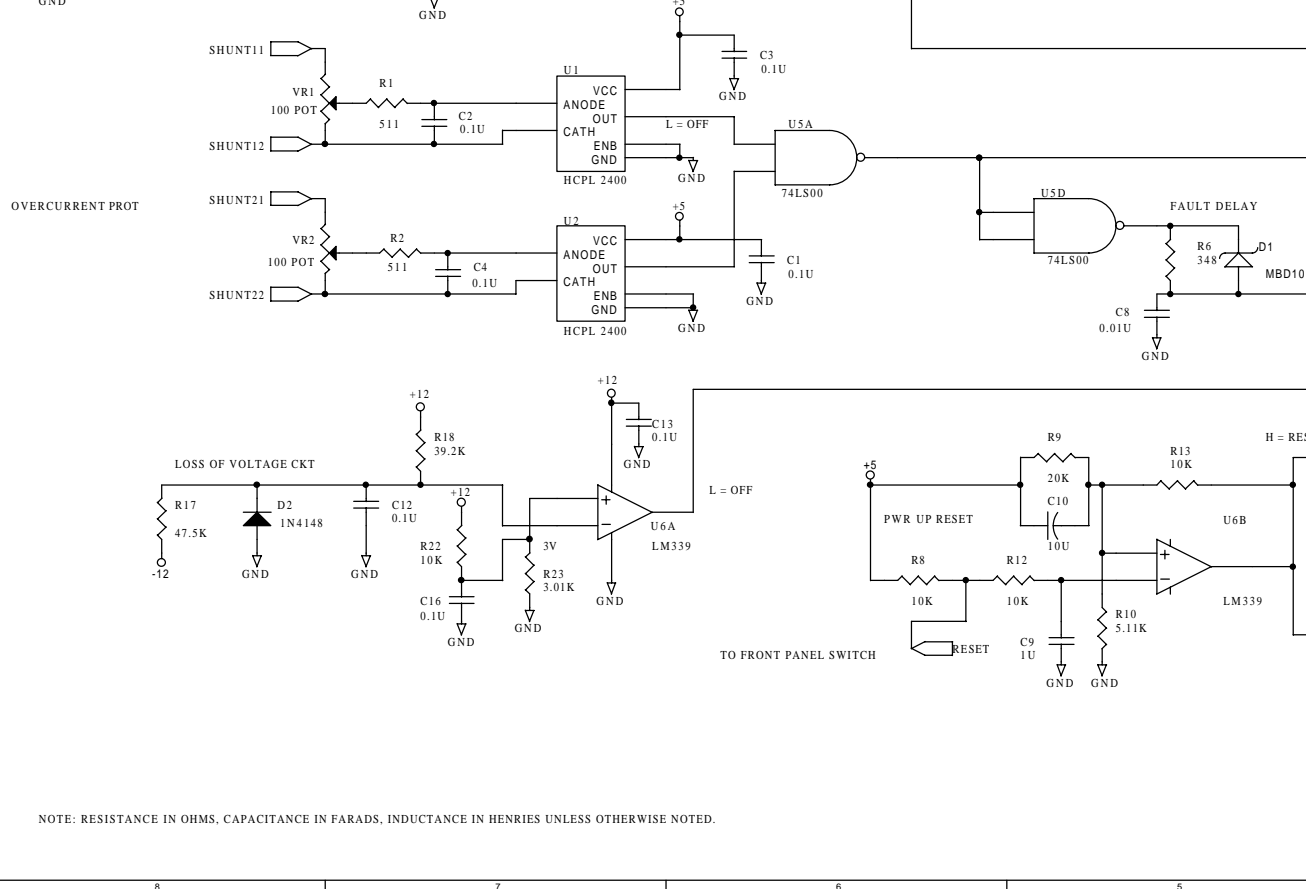
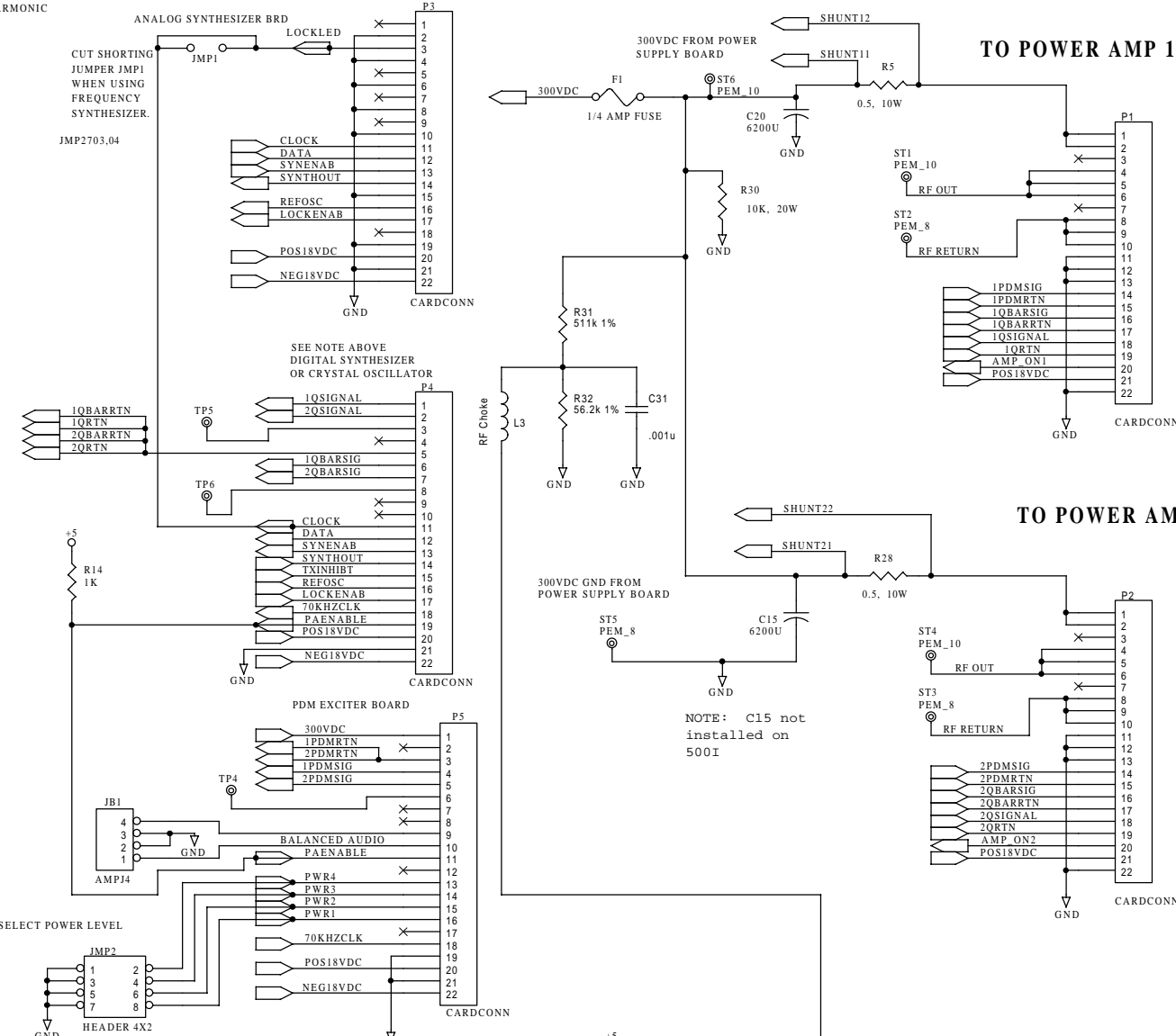

NOTE: RESISTANCE IN OHMS, CAPACITANCE IN FARADS, INDUCTANCE IN HENRIES UNLESS OTHERWISE NOTED.

<b>LPB Communications Inc</b> 960 Brook Road Unit #5 Conshohocken PA 19428		
Title	Omni 500i/1000i Motherboard	
Size	Document Number	Rev
C	S-L2-000	1
Date:	Sunday, December 29, 2002	Sheet 1 of 1