

REV	DESCRIPTION	DATE	APPROVED
1	SEE CHANGE ORDER 1110-01	02-08-91	DLSOLT
2	MOVED VAC2 THRU K2 .CB1009 TO 5A	3-25-92	JJSOLT
3	CORRECTED VAC2, CLARIFIED DWG	2-11-93	JJSOLT
4	EXT REVISED ADDED DUAL TRFMRS	6-30-95	JJSOLT
5	REMOVED RV2, C1008, UPDATED CONNECTORS	3-27-00	RWBORTH

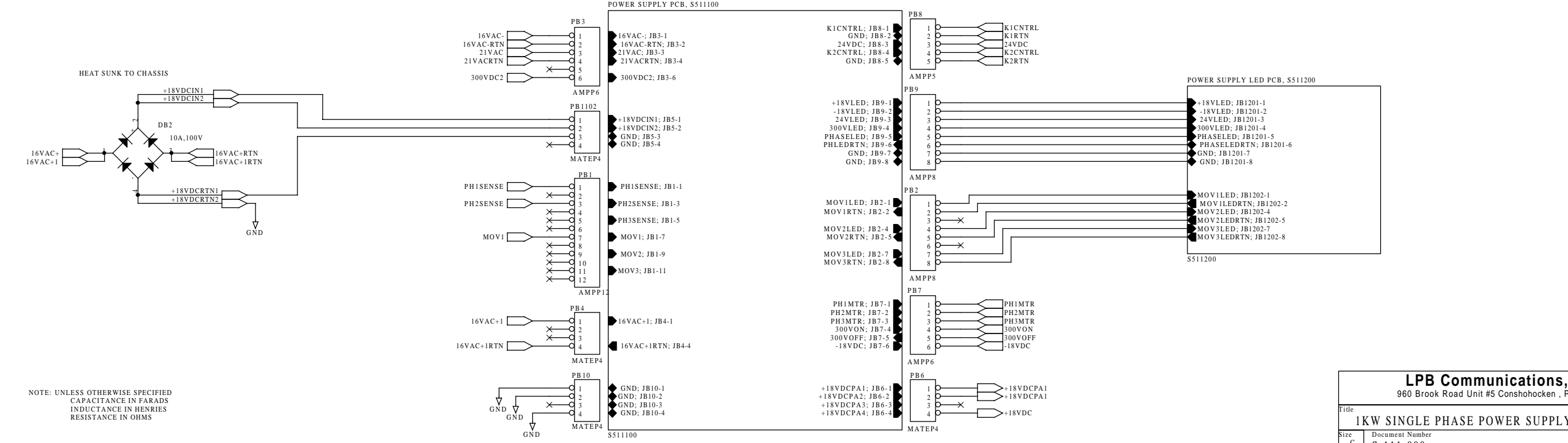
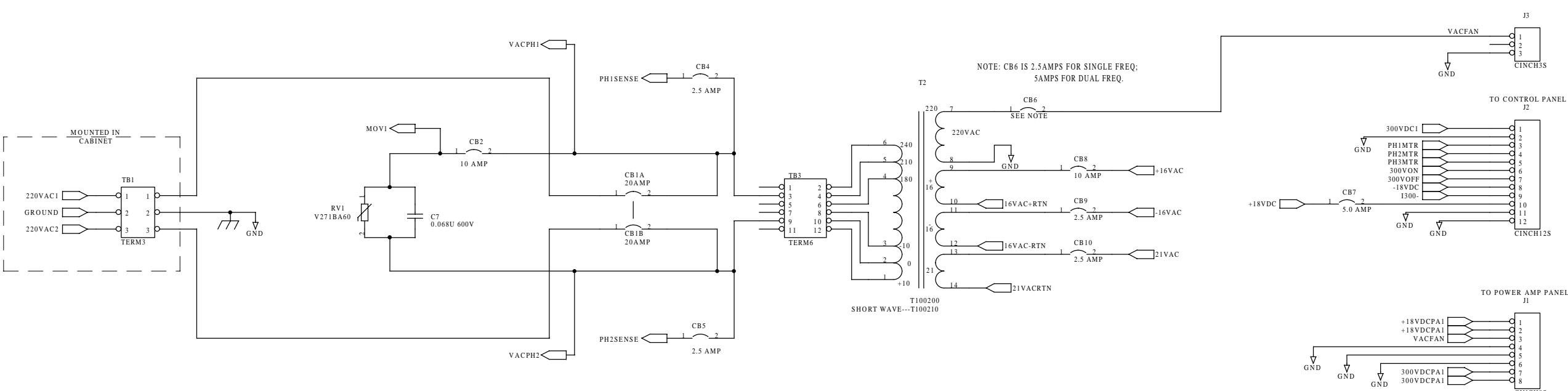
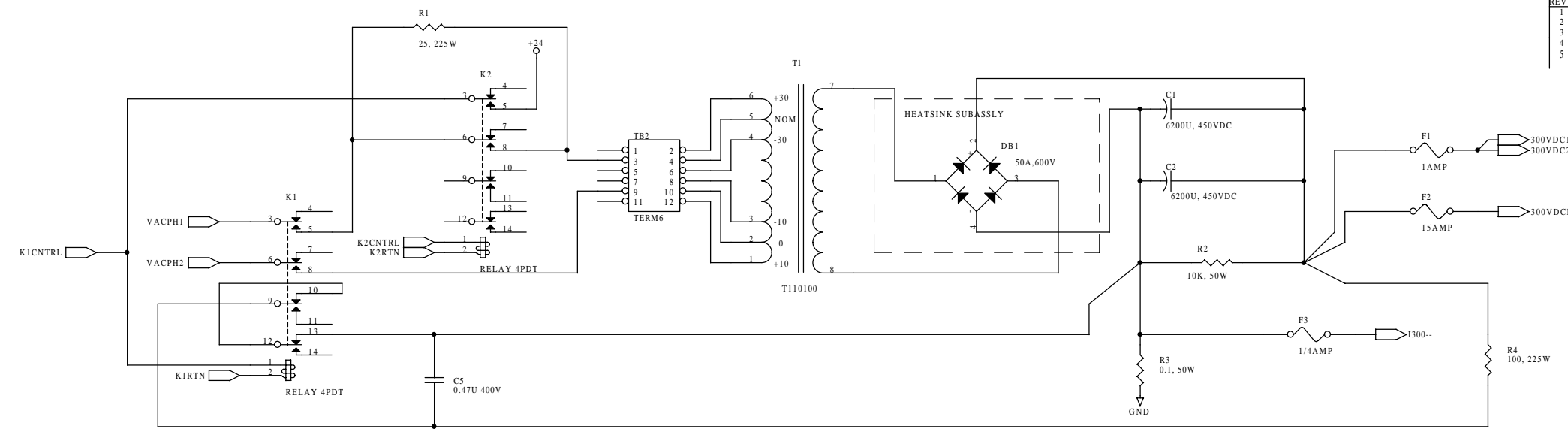

NOTE: UNLESS OTHERWISE SPECIFIED  
CAPACITANCE IN FARADS  
INDUCTANCE IN HENRIES  
RESISTANCE IN OHMS

**LPB Communications, Inc.**  
960 Brook Road Unit #5 Conshohocken, PA 19428

Title: **1KW SINGLE PHASE POWER SUPPLY PANEL**

Size: C Document Number: S-111-000 Rev: 5

Date: Sunday, November 03, 2002 Sheet: 1 of 1