

REVISIONS

REV	DESCRIPTION	DATE	APPROVED
-	corrected 16VAC+RTN from pin 11 to pin 9 of T2	10.31.02	JB

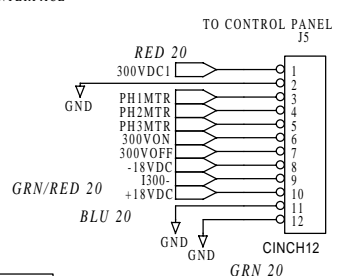
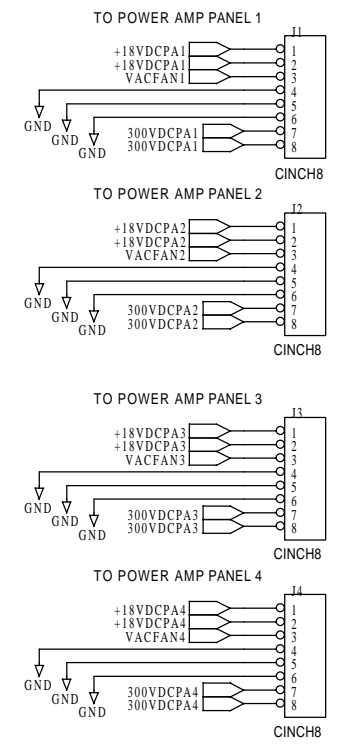
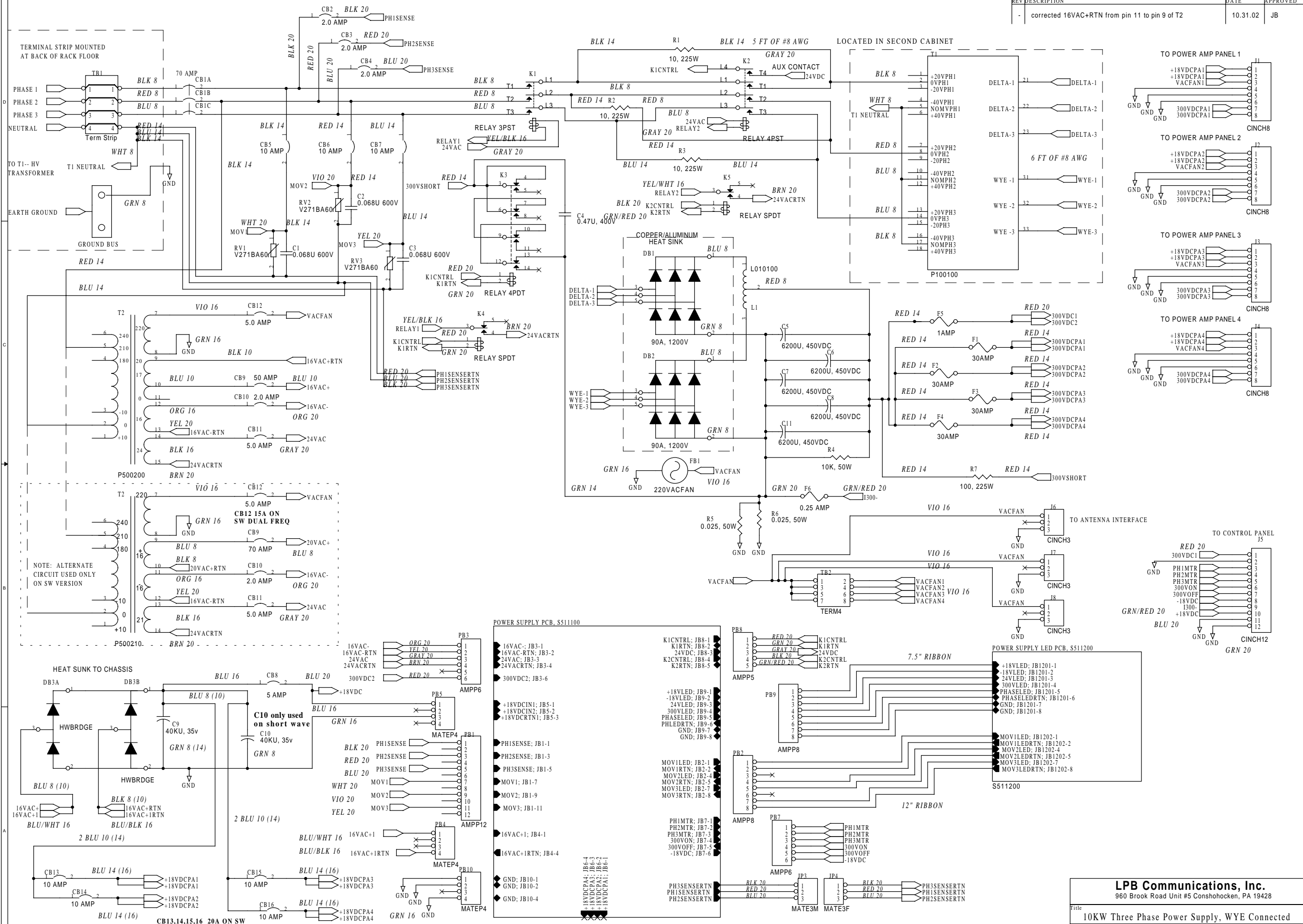

NOTE: Unless otherwise specified, Capacitance in Farads, Inductance in Henries, Resistance in Ohms.

**LPB Communications, Inc.**  
 960 Brook Road Unit #5 Conshohocken, PA 19428

Title: 10KW Three Phase Power Supply, WYE Connected

Size: C Document Number: S-011-001-Y Rev: 0

Date: Thursday, October 31, 2002 Sheet: 1 of 1